







SMT POWER INDUCTORS

Shielded Drum Core - PL95XX Series.
Ruggedized



-  Height: 0.122 inches (3.1mm) Max
-  Footprint: 0.256 inches x 0.256 inches (6.5mm x 6.5mm) Max
-  Inductance Range: 2.15 μ H to 85.39 μ H
-  Current Rating: up to 2.60A
-  Moisture Sensitivity Level: 1
-  Max Reflow Temp: 235°C
-  Storage Temp: -55°C to +130°C

Electrical Specifications @ 25°C — Operating Temperature -55°C to +130°C

Part Numbers	Inductance @I _{rated} (μ H TYP)	I _{rated} ² (A)	DCR (m Ω)		Inductance @0A _{DC} (μ H)	Saturation ³ Current (A) @25°C	Heating ⁴ Current (A)
			TYP	MAX			
PL9501	2.15	2.60	15.3	17.6	2.5*	2.60	3.45
PL9502	2.58	2.30	16.6	20.3	3.3*	2.30	3.31
PL9503	3.43	2.10	22.5	27.0	4.0*	2.10	2.84
PL9504	4.63	1.85	24.9	31.1	5.0*	1.85	2.70
PL9505	5.22	1.70	32.3	41.9	6.0*	1.70	2.37
PL9506	6.57	1.50	37.9	49.9	8.0*	1.50	2.19
PL9507	8.65	1.30	45	54	10	1.30	2.01
PL9508	9.78	1.20	59	72	12	1.20	1.76
PL9509	12.13	1.10	66	82	15	1.10	1.65
PL9510	15.23	1.05	88	102	18	1.05	1.44
PL9511	18.70	0.95	103	119	22	0.95	1.33
PL9512	21.54	0.85	114	146	27	0.85	1.26
PL9513	27.71	0.76	155	183	33	0.76	1.08
PL9514	33.57	0.68	193	210	39	0.68	0.97
PL9515	40.15	0.60	196	230	47	0.60	0.96
PL9516	49.68	0.55	248	305	56	0.55	0.86
PL9517	60.66	0.48	278	351	68	0.48	0.81
PL9518	74.71	0.45	323	419	82	0.45	0.75
PL9519	85.39	0.40	417	520	100	0.40	0.66

*Inductance at 0A_{DC} tolerance on indicated part numbers is \pm 30%; tolerance is \pm 20% on all other parts. Optional Tape & Reel packaging can be ordered by adding a "T" suffix to the part number (i.e. PL9501 becomes PL9501T).

NOTES FROM TABLE: (See back page)

*Inductance at 0ADC tolerance on indicated part numbers is \pm 30%; tolerance is \pm 20% on all other parts.

Optional Tape & Reel packaging can be ordered by adding a "T" suffix to the part number (i.e. PL9501 becomes PL9501T).

NOTES FROM TABLE: (See next page)

SMT POWER INDUCTORS

Shielded Drum Core - PL95XX Series.

Ruggedized



Notes from Tables

1. Temperature of the component (ambient plus temperature rise) must be within specified operating temperature range.
2. The rated current as listed is either the saturation current or the heating current depending on which value is lower.
3. The saturation current is the current which causes the inductance to drop to 75% of its initial inductance at zero bias. This current is determined by placing the component at room ambient (25°C), and applying a short duration pulse current (to eliminate self-heating effects) to the component.
4. The heating current is the DC current, which causes the temperature of the part to increase by approximately 40°C. This current is determined by extending the terminals of the component with 30mm length 28 gauge buss wires and applying the current to the device for 30 minutes. The temperature is measured by placing the thermocouple between the winding and the shield.
5. In high volt*time applications, additional heating in the component can occur due to core losses in the inductor which may necessitate derating the current in order to limit the temperature rise of the component. In order to determine the approximate total loss (or temperature rise) for a given application, both copper losses and core losses should be taken into account.

Mechanical

PL95XX

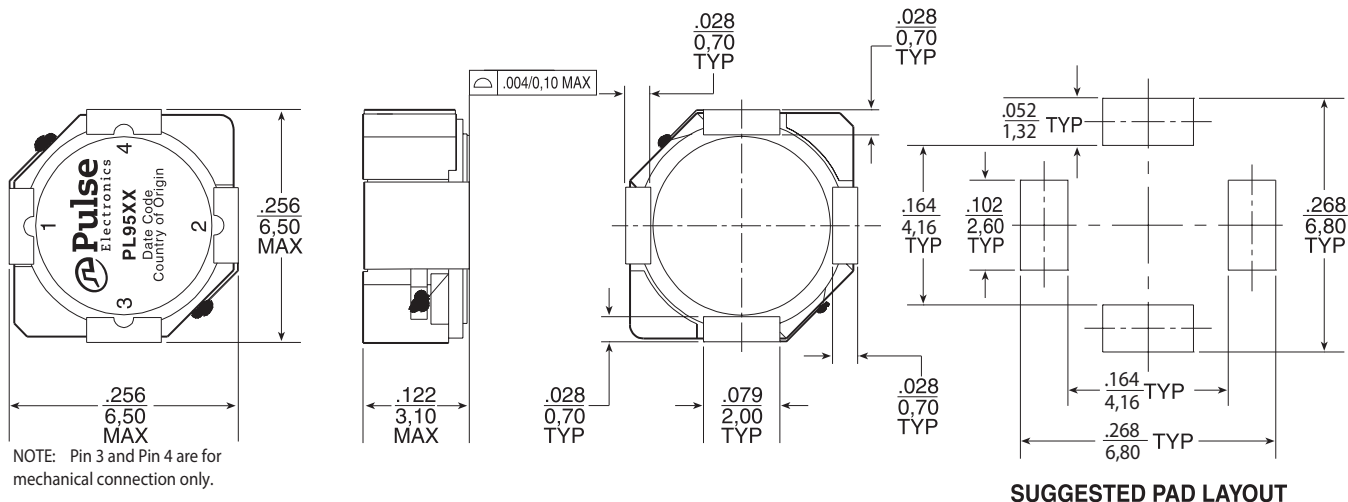

Schematic

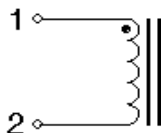

TAPE & REEL LAYOUT

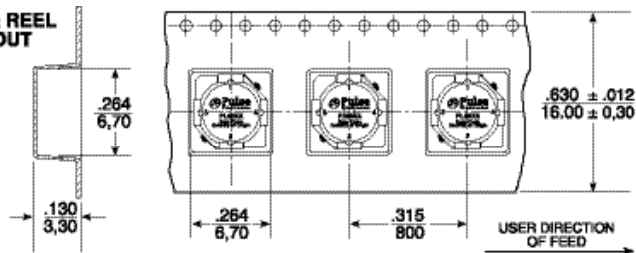

Weight 0.6 grams

Tape & Reel 2200/reel

Dimensions: Inches

mm

Unless otherwise specified,
all tolerances are ± .010
0.25

Inductance vs Current Characteristics

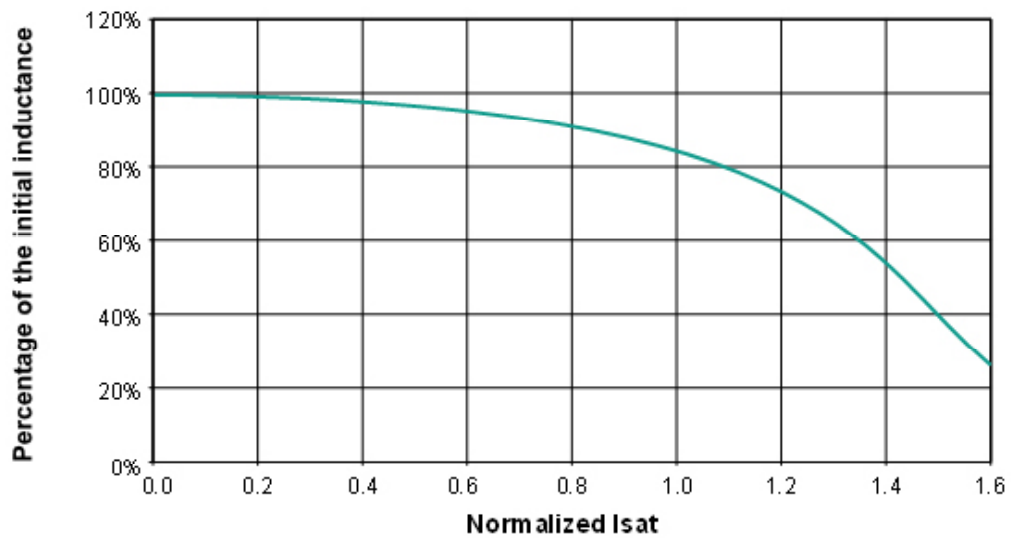

Transceiver Tin/Lead Recommended Reflow Profile (Based on J-STD-020D)

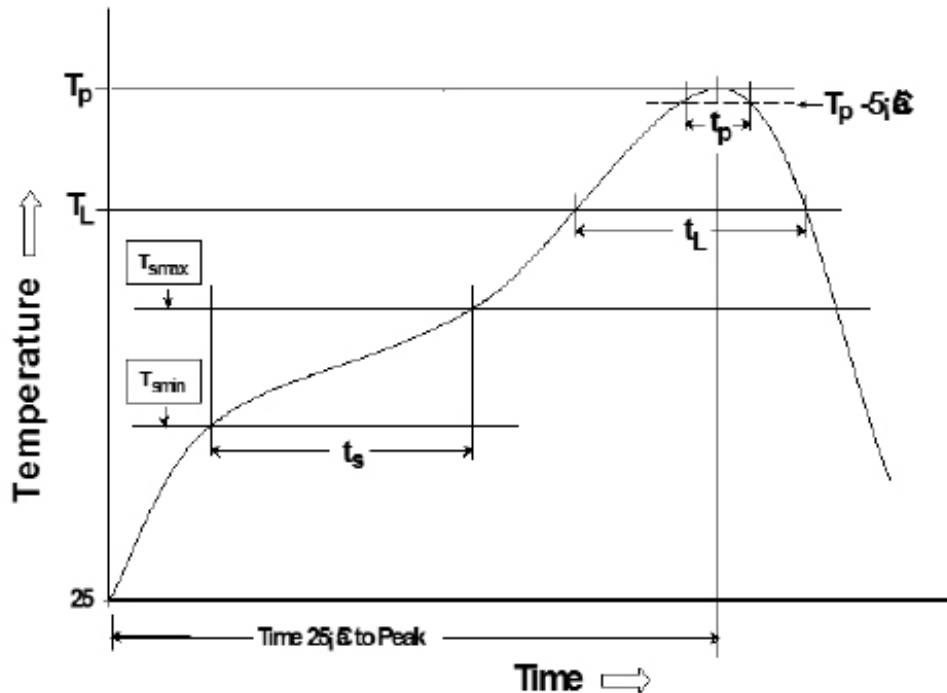

T_{SMIN} (°C)	T_{SMAX} (°C)	T_L (°C)	T_P (°C MAX)	t_s (s)	t_L (s)	t_p (s MAX)	Ramp-up rate (T_L to T_P)	Ramp-down rate (T_P to T_L)	Time 25°C to peak temperature (s MAX)
100	150	183	225	60-120	60-150	20	3°C/s MAX	6°C/s MAX	360

Notes:

1. All temperatures measured on the package leads.
2. Maximum times of reflow cycle: 2.

For More Information

Pulse North America
Headquarters
Two Pearl Buck Court
Bristol, PA 19007
U.S.A.

For Global Sales Representatives and Locations Visit:
<http://www.pulseruggedized.com>

Tel: +1.215. 781. 6400
Fax: +1.215. 781. 6403

Performance warranty of products offered on this data sheet is limited to the parameters specified. Data is subject to change without notice. Other brand and product names mentioned herein may be trademarks or registered trademarks of their respective owners. © Copyright, 2018. PulseR, LLC. All rights reserved.